



Austrian Institute of Construction Engineering  
 Schenkenstrasse 4 | T+43 1 533 65 50  
 1010 Vienna | Austria | F+43 1 533 64 23  
 www.oib.or.at | mail@oib.or.at



## European Technical Assessment

**ETA-12/0119**  
 of 04.05.2021

General part

**Technical Assessment Body issuing the European Technical Assessment**

Österreichisches Institut für Bautechnik (OIB)  
 Austrian Institute of Construction Engineering

**Trade name of the construction product**

ZZ G50

**Product family to which the construction product belongs**

Fire Stopping and Fire Sealing Products:  
 Linear Joint and Gap Seals

**Manufacturer**

ZZ Brandschutz GmbH & Co. KG  
 Marconistraße 7-9  
 50769 Köln  
 GERMANY

**Manufacturing plant**

Werk 1

**This European Technical Assessment contains**

20 pages including Annexes A-1 to F-2 which form an integral part of this assessment.

**This European Technical Assessment is issued in accordance with Regulation (EU) No 305/2011, on the basis of**

European Assessment Document  
 EAD 350141-00-1106 "Fire stopping and fire sealing products – Linear joint and gap seals"

**This European Technical Assessment replaces**

European Technical Assessment ETA-12/0119 of 19.07.2017

This European Technical Assessment is not to be transferred to manufacturers or agents of manufacturer other than those indicated on page 1, or manufacturing plants other than those laid down in the context of this European Technical Assessment.

Translations of this European Technical Assessment in other languages shall fully correspond to the original issued document and should be identified as such.

Communication of this European Technical Assessment, including transmission by electronic means, shall be in full. However, partial reproduction can be made with the written consent of the Österreichisches Institut für Bautechnik. In this case, partial reproduction has to be designated as such.

This European Technical Assessment may be withdrawn by the Österreichisches Institut für Bautechnik, in particular pursuant to information by the Commission according to Article 25 (3) of Regulation (EU) No 305/2011.

electronic copy  
electronic copy  
electronic copy  
electronic copy  
electronic copy  
electronic copy  
electronic copy

Specific parts

## 1 Technical description of the product

“ZZ G50” is a kit to be used as a linear joint and gap seal based on the following component.

Component of “ZZ G50”	Characteristics
ZZ 530	Compressible intumescent strip on the basis of polyurethane with intumescent fire protection additives (fire protection joint seal)

## 2 Specification of the intended use(s) in accordance with the applicable European Assessment Document (hereinafter EAD)

### 2.1 Intended use

“ZZ G50” is intended to be used as a linear joint and gap seal to reinstate the fire resistance performance of rigid wall constructions and rigid floor constructions at linear gaps/joints within those constructions or where they are abutting another wall or floor/ceiling/roof construction.

The maximum gap/joint width of the linear joint and gap seal has to comply with the dimensions as specified in the following table.

“ZZ G50” can be installed only in construction elements as specified in the following table.

Construction-element	Construction
Rigid walls	<ul style="list-style-type: none"><li>&gt; Aerated concrete, concrete, reinforced concrete, masonry</li><li>&gt; Minimum density 600 kg/m<sup>3</sup></li><li>&gt; Minimum thickness 125 mm</li><li>&gt; The rigid wall shall be classified in accordance with EN 13501-2 for the required fire resistance period</li><li>&gt; Maximum joint width 75 mm</li></ul>
Rigid floors	<ul style="list-style-type: none"><li>&gt; Aerated concrete, concrete, reinforced concrete</li><li>&gt; Minimum density 600 kg/m<sup>3</sup></li><li>&gt; Minimum thickness 150 mm</li><li>&gt; The rigid floor shall be classified in accordance with EN 13501-2 for the required fire resistance period</li><li>&gt; Maximum joint width 75 mm</li></ul>

### 2.2 Use conditions

“ZZ G50” is intended for use at temperatures below 0 °C with casual exposure to UV but no exposure to rain, and can therefore - according to EAD 350141-00-1106, clause 2.1 - be categorized as Type Y<sub>1</sub>. Since the requirements for Type Y<sub>1</sub> are met, also the requirements for the Types Y<sub>2</sub>, Z<sub>1</sub>, and Z<sub>2</sub> are fulfilled.

### 2.3 Working life

The provisions made in this European Technical Assessment are based on an assumed working life of “ZZ G50” of 10 years, provided the conditions laid down in the technical literature of the manufacturer relating to packaging, transport, storage, installation, use and repair are met.

The indications given on the intended working life cannot be interpreted as a guarantee given by the producer or the Technical Assessment Body, but are to be regarded only as a means for selecting the appropriate product in relation to the expected economically reasonable working life of the works.

The real working life might be, in normal use conditions, considerably longer without major degradation affecting the Basic requirements for construction works.

#### **2.4 General assumptions**

It is assumed that damages to the linear joint and gap seal are repaired accordingly.

#### **2.5 Manufacturing**

The European Technical Assessment is issued for the product on the basis of agreed data / information, deposited with the Österreichisches Institut für Bautechnik, which identifies the product that has been assessed and judged. Changes to the product or production process, which could result in this deposited data / information being incorrect, should be notified to the Österreichisches Institut für Bautechnik before the changes are introduced.

The Österreichisches Institut für Bautechnik will decide whether or not such changes affect the European Technical Assessment and consequently the validity of the CE marking on the basis of the European Technical Assessment and if so whether further assessment or alterations to the European Technical Assessment, shall be necessary.

#### **2.6 Installation**

The product shall be installed and used as described in this European Technical Assessment.

### 3 Performance of the product and references to the methods used for its assessment

Basic requirements for construction works	Essential characteristic	Method of verification	Performance
<b>BWR 2</b>	Reaction to fire	EN 13501-1:2007	Clause 3.1.1 of the ETA
	Resistance to fire	EN 13501-2:2007+A1:2009	Annex B-1 to E-2 of the ETA
<b>BWR 3</b>	Content, emission and/or release of dangerous substances	prEN 16516:2015	Clause 3.2.1 of the ETA
	Air permeability (material property)	No performance assessed	
	Water permeability (material property)	No performance assessed	
<b>BWR 4</b>	Mechanical resistance and stability	No performance assessed	
	Resistance to impact / movement	No performance assessed	
	Adhesion	No performance assessed	
	Durability	EAD 350141-00-1106 clause 2.2.3	Clause 3.3.4 of the ETA
	Movement capability	No performance assessed	
	Cycling of perimeter seals for curtain walls	No performance assessed	
	Compression set	No performance assessed	
	Linear expansion on setting	No performance assessed	
<b>BWR 5</b>	Airborne sound insulation	No performance assessed	
<b>BWR 6</b>	Thermal properties	EN 12667:2001	Clause 3.5.1 of the ETA
	Water vapour permeability	No performance assessed	

#### 3.1 Safety in case of fire (BWR 2)

##### 3.1.1 Reaction to fire

The components of "ZZ G50" were assessed according to the EAD, clause 2.2.1 and classified according to EN 13501-1:2007.

Component	Class according to EN 13501-1:2007
ZZ 530	E

##### 3.1.2 Resistance to fire

"ZZ G50" was tested according to EAD clause 2.2.2, EN 1366-4:2006+A1:2010, installed within linear joints in rigid walls and rigid floors.

Based upon the gained test results and the field of application specified within EN 1366-4:2006+A1:2010 "ZZ G50" has been classified according to EN 13501-2:2007+A1:2009.

The resistance to fire classification listed in Annex B-1 to E-2 of the ETA is only valid if “ZZ G50” is installed according to Annex A-1 to A-2 and B-1 to E-2 of the ETA.

### 3.2 Hygiene, health and the environment (BWR 3)

#### 3.2.1 Content, emission and/or release of dangerous substances

The release of semi-volatile organic compounds (SVOC) and volatile organic compounds (VOC) has been assessed for “ZZ G50” according to the EAD, clause 2.2.3 and prEN 16516:2015. Deviating from the specifications of the EAD, the tests were performed with a loading factor of 0,05 m<sup>2</sup>/m<sup>3</sup>.

Component	Total emission of SVOC after 3 days in mg/m <sup>3</sup>	Total emission of SVOC after 28 days in mg/m <sup>3</sup>
ZZ 530	< 0,005	< 0,005

Component	Total emission of VOC after 3 days in mg/m <sup>3</sup>	Total emission of VOC after 28 days in mg/m <sup>3</sup>
ZZ 530	0,008	0,006

#### 3.2.2 Air permeability

No performance assessed.

#### 3.2.3 Water permeability

No performance assessed.

### 3.3 Safety and accessibility in use (BWR 4)

#### 3.3.1 Mechanical resistance and stability

No performance assessed.

#### 3.3.2 Resistance to impact / movement

No performance assessed.

#### 3.3.3 Adhesion

No performance assessed.

#### 3.3.4 Durability

All components of “ZZ G50” fulfil the requirements for the intended use condition.

“ZZ G50” is therefore appropriate for use at temperatures below 0 °C with casual exposure to UV but no exposure to rain, and can therefore - according to EAD 350141-00-1106, clause 2.1 - be categorized as Type Y<sub>1</sub>. Since the requirements for Type Y<sub>1</sub> are met, also the requirements for the Types Y<sub>2</sub>, Z<sub>1</sub>, and Z<sub>2</sub> are fulfilled.

#### 3.3.5 Movement capability

No performance assessed.

#### 3.3.6 Cycling of perimeter seals for curtain walls

No performance assessed.

3.3.7 Compression set

No performance assessed.

3.3.8 Linear expansion on setting

No performance assessed.

**3.4 Protection against noise (BWR 5)**

3.4.1 Airborne sound insulation

No performance assessed.

**3.5 Energy economy and heat retention (BWR 6)**

3.5.1 Thermal properties

The thermal properties of fire protection joint seal “ZZ 530” were tested according to EN 12667:2001.

Component	$\lambda_{10,23/50}$ in W/(m*K)
ZZ 530	0,103

3.5.2 Water vapour permeability

No performance assessed.

**4 Assessment and verification of constancy of performance (hereinafter AVCP) system applied, with reference to its legal base**

According to the Decision 1999/454/EC<sup>1</sup>, amended by Decision 2001/596/EC<sup>2</sup> of the European Commission the system(s) of assessment and verification of constancy of performance (see Annex V of Regulation (EU) No 305/2011) is given in the following table.

Product(s)	Intended use(s)	Level(s) or class(es) (resistance to fire)	System of assessment and verification of constancy of performance
Fire Stopping and Fire Sealing Products	for fire compartmentation and/or fire protection or fire performance	any	1

In addition, according to the Decision 1999/454/EC, amended by Decision 2001/596/EC of the European Commission the system(s) of assessment and verification of constancy of performance, with regard to reaction to fire, is 3.

<sup>1</sup> Official Journal of the European Communities no. L 178, 14.7.1999, p. 52

<sup>2</sup> Official Journal of the European Communities no. L 209, 2.8.2001, p. 33

<b>Product(s)</b>	<b>Intended use(s)</b>	<b>Level(s) or class(es)</b> (reaction to fire)	<b>System</b> of assessment and verification of constancy of performance
Fire Stopping and Fire Sealing Products	For uses subject to regulations on reaction to fire	A1*, A2*, B*, C*	1
		A1**, A2**, B**, C**, D, E	3
		(A1 to E)***, F	4
* Products/materials for which a clearly identifiable stage in the production process results in an improvement of the reaction to fire classification (e.g. an addition of fire retardants or a limiting of organic material)			
** Products/materials not covered by footnote (*)			
*** Products/materials that do not require to be tested for reaction to fire (e.g. products/materials of class A1 according to Commission Decision 96/603/EC, as amended)			

**5 Technical details necessary for the implementation of the AVCP system, as provided for in the applicable EAD**

Technical details necessary for the implementation of the AVCP system are laid down in the control plan deposited with the Technical Assessment Body Österreichisches Institut für Bautechnik.

The notified product certification body shall visit the factory at least twice a year for surveillance of the manufacturer.

Issued in Vienna on 04.05.2021  
by Österreichisches Institut für Bautechnik

The original document is signed by:

Rainer Mikulits  
Managing Director

electronic copy electronic copy electronic copy electronic copy electronic copy electronic copy electronic copy electronic copy electronic copy electronic copy

**1 General**

- > “ZZ G50” can be used in joints and gaps in wall constructions (vertical separating element) and floor constructions (horizontal separating element) according to clause 2.1 of the ETA.
- > It must be ensured that the installation of the linear joint and gap seal does not affect the stability of the adjacent building element – even in case of fire.
- > The use of a silicone sealant including primer for the application according to Annex C-1 to D-2 of the ETA is required.
- > The use of additional sealant (e.g. silicone, acrylic, MS hybrid polymer, polyurethane, polyurethane hybrid, polysulfide, butyl) for the application according to Annex B-1 to B-2 and E-1 to E-2 of the ETA is allowed.

**2 Details for installation of “ZZ G50” (see Annex B-1 to E-2 of the ETA)**

- > “ZZ G50” has to be installed according to the ETA-holder’s installation instructions.
- > The surfaces to which “ZZ G50” will be applied must be cleaned of loose debris and dirt.
- > Material that is located in the joint can remain, provided that the fire protection joint seal “ZZ 530” can be inserted completely from both sides according to the ETA-holder’s installation instructions.
- > “ZZ G50” will be formed by compressing and inserting the fire protection joint seal “ZZ 530” into the component joint. In this process, the linear joint and gap seal must not be twisted or overstretched.
- > Fire protection joint seal “ZZ 530” has to be butt-jointed together. According to the ETA-holder’s installation instructions the use of adhesive is not necessary.
- > For the application according to Annex B-1 and B-2 of the ETA, one fire protection joint seal “ZZ 530” must be mounted flush to the component surface on each side.
- > For the application according to Annex C-1 and C-2 of the ETA, one fire protection joint seal “ZZ 530” must be mounted on one side of the component and has to be sealed with a silicone sealant. The depth of the sealant has to be minimum 6 mm resp. 10 mm. On the other side the joint has to be sealed with a backfilling material (PE round cord or mineral wool) and a silicone sealant (seal depth minimum 6 mm resp. 10 mm).
- > For the application according to Annex D-1 and D-2 of the ETA, one fire protection joint seal “ZZ 530” must be mounted flush to the component surface on one side. On the other side the joint has to be sealed with a backfilling material (PE round cord or mineral wool) and a silicone sealant (seal depth minimum 6 mm resp. 10 mm).
- > For a joint width  $\geq 55$  mm, it is possible to push the linear joint and gap seal into the interior of the component joint according to Annex E-1 and E-2 of the ETA.

**ZZ G50**

- Details for installation -

**ANNEX A-1**

electronic copy electronic copy electronic copy electronic copy electronic copy electronic copy electronic copy electronic copy electronic copy electronic copy

**3 Transport and storage**

- > The indications of the manufacturer regarding transport and storage (minimum and maximum storing temperature, maximum duration of storage) have to be followed.

**4 Use, maintenance and repair**

- > The fire resistance of the linear joint and gap seal shall not be negatively affected by future changes to buildings or building elements.
- > The assessment of the fitness for use is based on the assumption that necessary maintenance and repair if required is carried out in accordance with the ETA-holder's installation instruction during the assumed intended working life.

**ZZ G50**

- Transport and storage -  
- Use, maintenance and repair -

**ANNEX A-2**

**Lateral movement capability 25 %, shear movement capability 7,5 %**  
**Option 1: Installation of two Fire Protection Joint Seals ZZ 530**

**Vertical joints in/ between rigid walls**

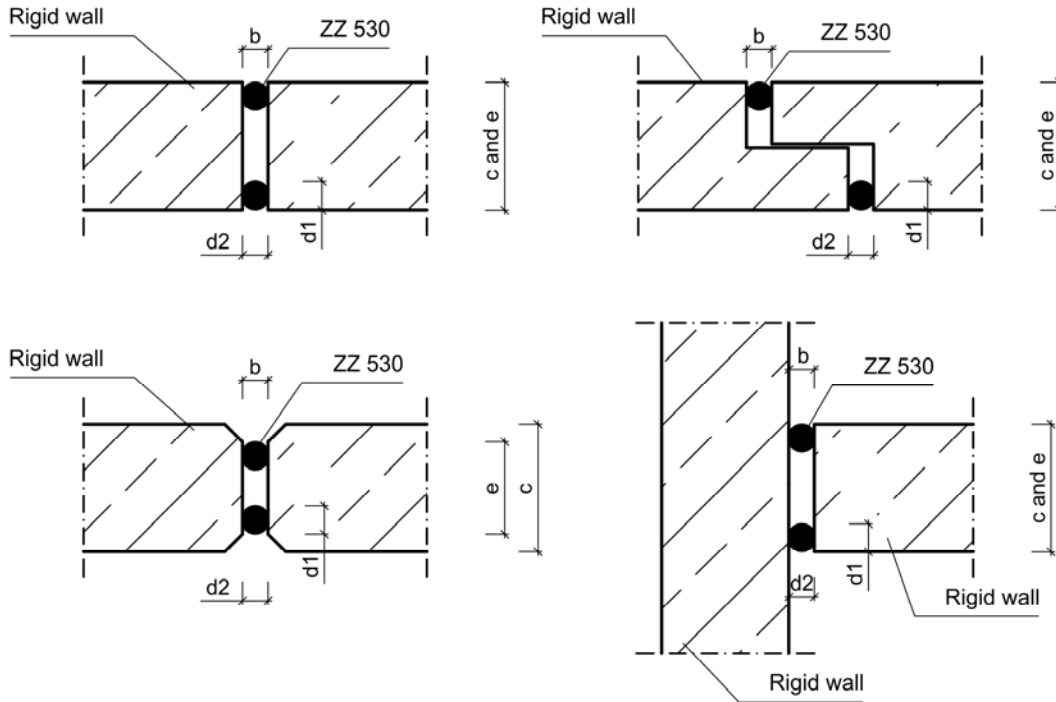

**Horizontal joints in rigid walls abutting a floor, ceiling or roof :**

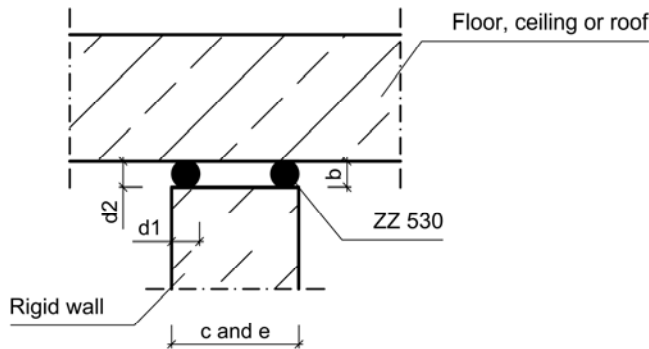

Considering the minimum overall seal depth (150 mm) Fire Protection Joint Seal ZZ 530 need not to be installed flush with the surface in case of rigid walls thicker than 150 mm.

All dimensions in mm

Element of construction	Joint width b [mm]	Wall thickness c/ Overall seal depth e [mm]	Height of ZZ 530 d1 [mm]	Width of ZZ 530 d2 [mm]	Fire resistance classification
Rigid wall	10 to 60	≥ 150	see ANNEX F-1 of the ETA	see ANNEX F-1 of the ETA	EI15- to EI120-V-M025-F-W 10 to 60 EI15- to EI120-T-M025-F-W 10 to 60

**ZZ G50**

**Lateral movement capability 25%, shear movement capability 7,5%**  
 - Option 1: Installation of two Fire Protection Joint Seals ZZ 530 -

**ANNEX B-1**

**Lateral movement capability 25 %, shear movement capability 7,5 %**  
**Option 1: Installation of two Fire Protection Joint Seals ZZ 530**

**Horizontal joints in/ between rigid floors**

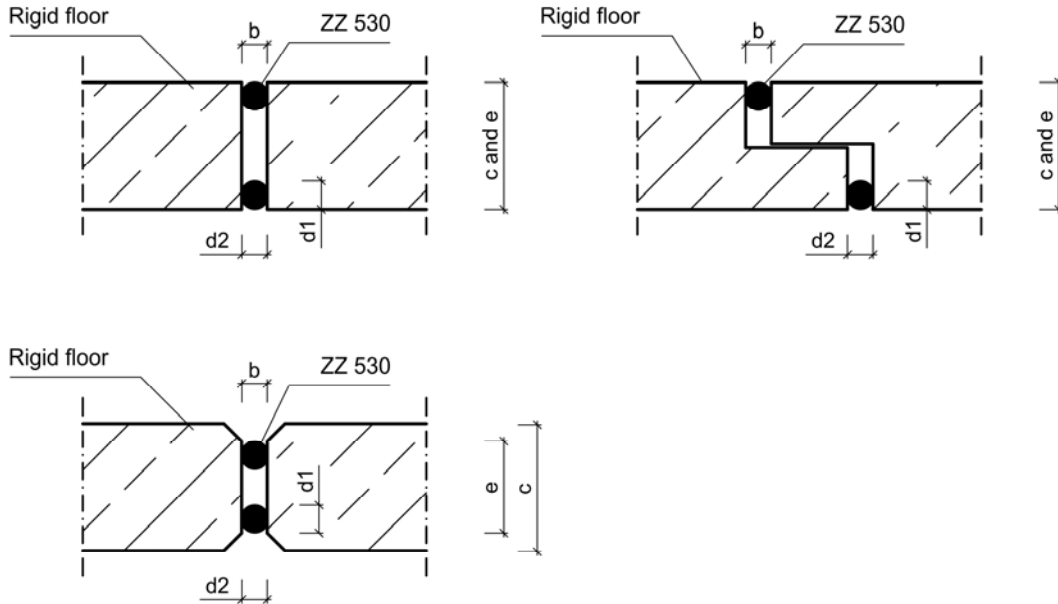

Considering the minimum overall seal depth (150 mm) Fire Protection Joint Seal ZZ 530 need not to be installed flush with the surface in case of rigid floors thicker than 150 mm.

All dimensions in mm

Element of construction	Joint width b [mm]	Floor thickness c/ Overall seal depth e [mm]	Height of ZZ 530 d1 [mm]	Width of ZZ 530 d2 [mm]	Fire resistance classification
Rigid floor	10 to 60	≥ 150	see ANNEX F-1 of the ETA	see ANNEX F-1 of the ETA	EI15- to EI120-H-M025-F-W 10 to 60

**ZZ G50**

**Lateral movement capability 25%, shear movement capability 7,5%**  
 - Option 1: Installation of two Fire Protection Joint Seals ZZ 530 -

**ANNEX B-2**

**Lateral movement capability 25 %, shear movement capability 7,5 %**  
**Option 2: Combination of Fire Protection Joint Seal ZZ 530 and silicone sealant**

**Vertical joints in/ between rigid walls**

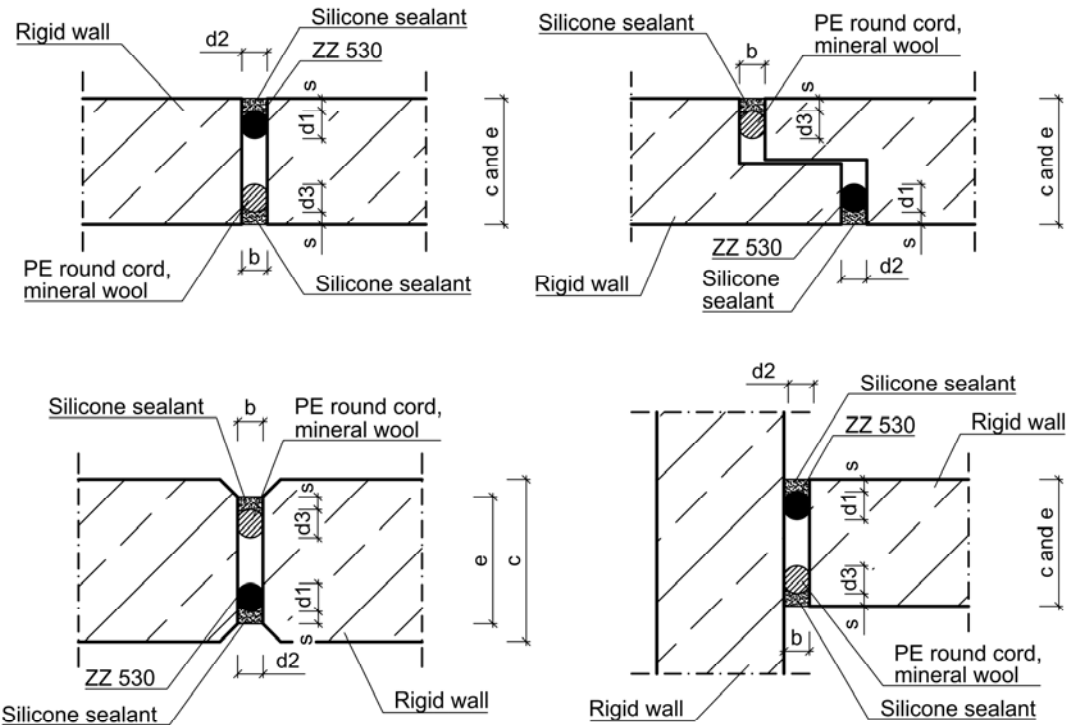

**Horizontal joints in rigid walls abutting a floor, ceiling or roof :**

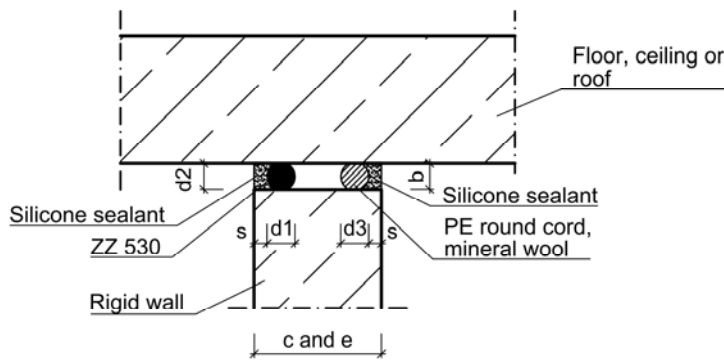

All dimensions in mm

Element of construction	Joint width b [mm]	Wall thickness c/ Overall seal depth e [mm]	Min. depth of sealant s [mm]	Min. depth of backfill d3 [mm]	Height and width of ZZ 530 d1 and d2 [mm]	Fire resistance classification
Rigid wall	10 to 36	≥ 125	≥ 6 mm, if b < 27mm ≥ 10 mm, if b > 27 mm	≥ 10	see ANNEX F-1 of the ETA	EI15- to EI120-V-M025-F-W 10 to 36 EI15- to EI120-T-M025-F-W 10 to 36

**ZZ G50**

**Lateral movement capability 25%, shear movement capability 7,5%**

- Option 2: Combination of Fire Protection Joint Seals ZZ 530 and silicone sealant -

**ANNEX C-1**

**Lateral movement capability 25 %, shear movement capability 7,5 %**  
**Option 2: Combination of Fire Protection Joint Seal ZZ 530 and silicone sealant**

**Horizontal joints in/ between rigid floors**

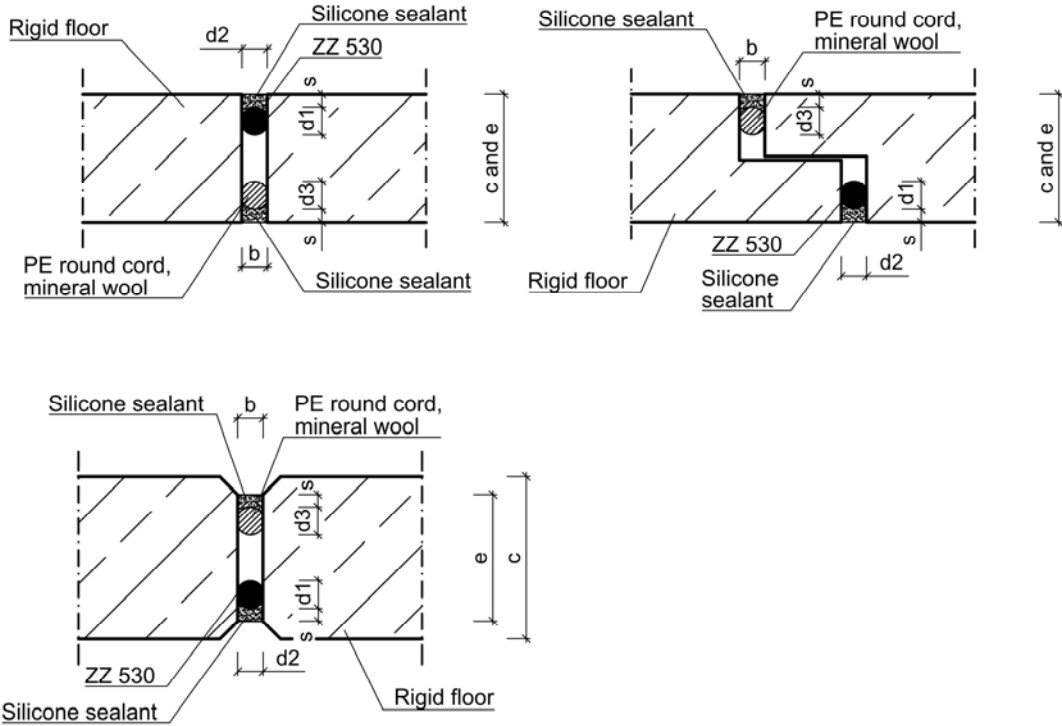

All dimensions in mm

Element of construction	Joint width b [mm]	Floor thickness c / Overall seal depth e [mm]	Min. depth of sealant s [mm]	Min. depth of backfill d3 [mm]	Height and width of ZZ 530 d1 and d2 [mm]	Fire resistance classification
Rigid floor	10 to 36	≥ 150	> 6 mm, if b ≤ 27mm > 10 mm, if b > 27 mm	≥ 10	see ANNEX F-1 of the ETA	EI15- to EI120-H-M025-F-W 10 to 36

**ZZ G50**

**Lateral movement capability 25%, shear movement capability 7,5%**

- Option 2: Combination of Fire Protection Joint Seals ZZ 530 and silicone sealant -

**ANNEX C-2**

**Lateral and shear movement capability 7,5 %**

**Option 3: Combination of Fire Protection Joint Seal ZZ 530 and silicone sealant**

**Vertical joints in/ between rigid walls**

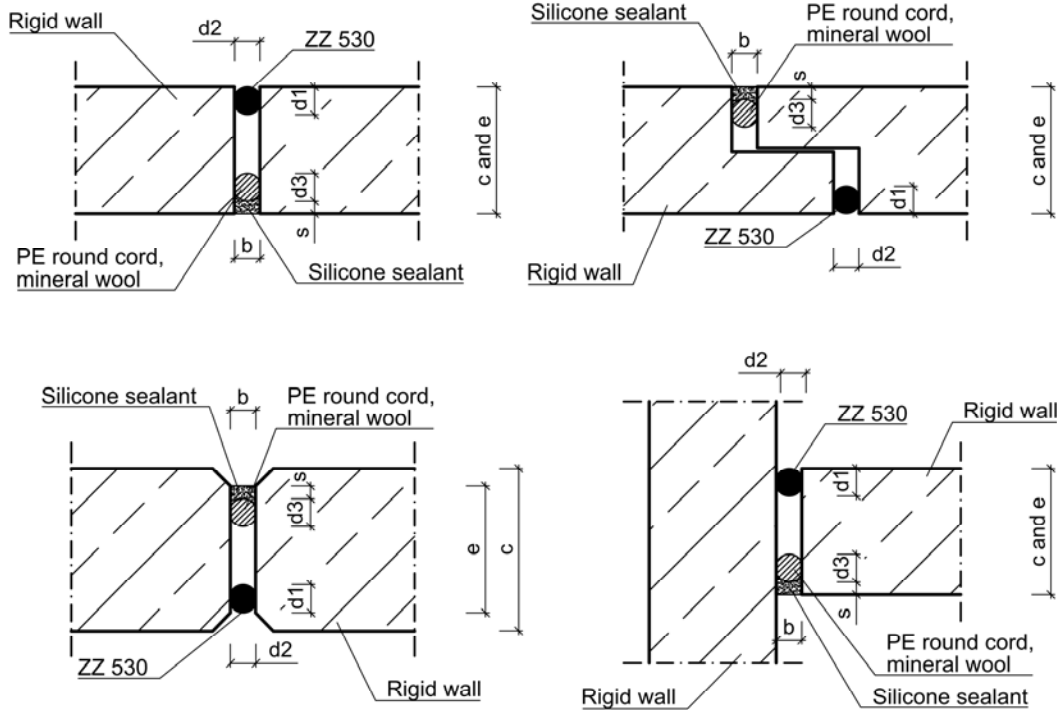

**Horizontal joints in rigid walls abutting a floor, ceiling or roof :**

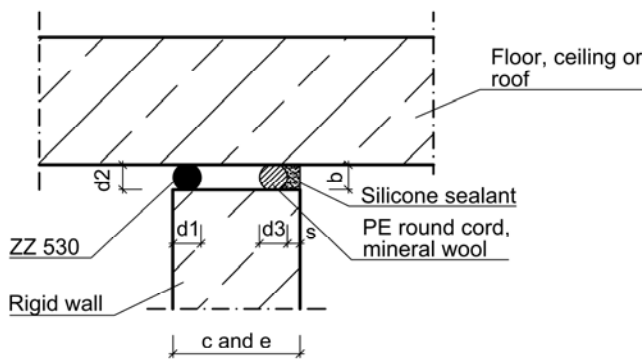

Considering the minimum overall seal depth e (125 mm or 150 mm) Fire Protection Joint Seal ZZ 530 need not to be installed flush with the surface in case of rigid walls thicker than 125 mm or 150 mm.

Element of construction	Joint width b [mm]	Wall thickness c/ Overall seal depth e [mm]	Min. depth of sealant s [mm]	Min. depth of backfill d3 [mm]	Height and width of ZZ 530 d1 and d2 [mm]	Fire resistance classification
Rigid wall	10 to 75	≥ 125	≥ 6 mm, if b < 27mm ≥ 10 mm, if b > 27 mm	≥ 10	see ANNEX F-2 of the ETA	EI15- to EI90-V-X-F-W 10 to 75 EI15- to EI90-T-X-F-W 10 to 75
		≥ 150	EI15- to EI120-V-X-F-W 10 to 75 EI15- to EI120-T-X-F-W 10 to 75			

**ZZ G50**

**Lateral and shear movement capability 7,5%**

- Option 3: Combination of Fire Protection Joint Seals ZZ 530 and silicone sealant -

**ANNEX D-1**

**Lateral and shear movement capability 7,5 %**  
**Option 3: Combination of Fire Protection Joint Seal ZZ 530 and silicone sealant**

**Horizontal joints in/ between rigid floors**

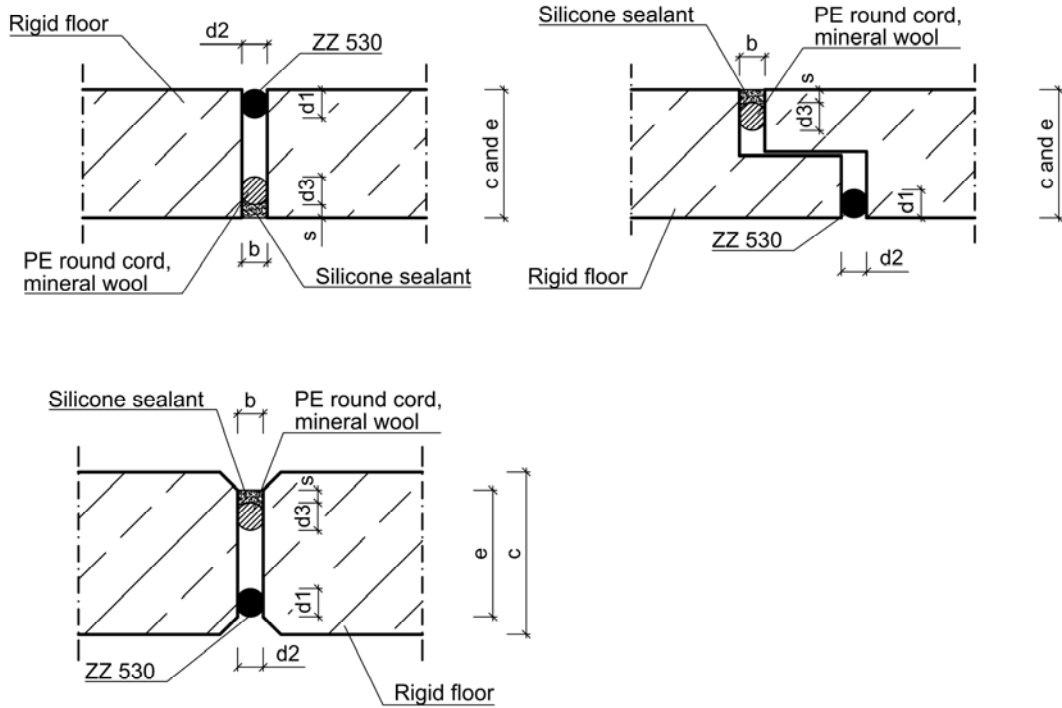

Considering the minimum overall seal depth e (150 mm) Fire Protection Joint Seal ZZ 530 need not to be installed flush with the surface in case of rigid floors thicker than 150 mm.

All dimensions in mm

Element of construction	Joint width b [mm]	Floor thickness c / Overall seal depth e [mm]	Min. depth of sealant s [mm]	Min. depth of backfill d3 [mm]	Height and width of ZZ 530 d1 and d2 [mm]	Fire resistance classification
Rigid floor	10 to 75	≥ 150	> 6 mm, if b ≤ 27mm > 10 mm, if b > 27 mm	≥ 10	see ANNEX F-2 of the ETA	EI15- to EI120-H-X-F-W 10 to 75

**ZZ G50**

**Lateral and shear movement capability 7,5%**

- Option 3: Combination of Fire Protection Joint Seals ZZ 530 and silicone sealant -

**ANNEX D-2**

**Lateral and shear movement capability 7,5 %**  
**Option 4: Installation of one Fire Protection Joint Seal ZZ 530**

**Vertical joints in/ between rigid walls**

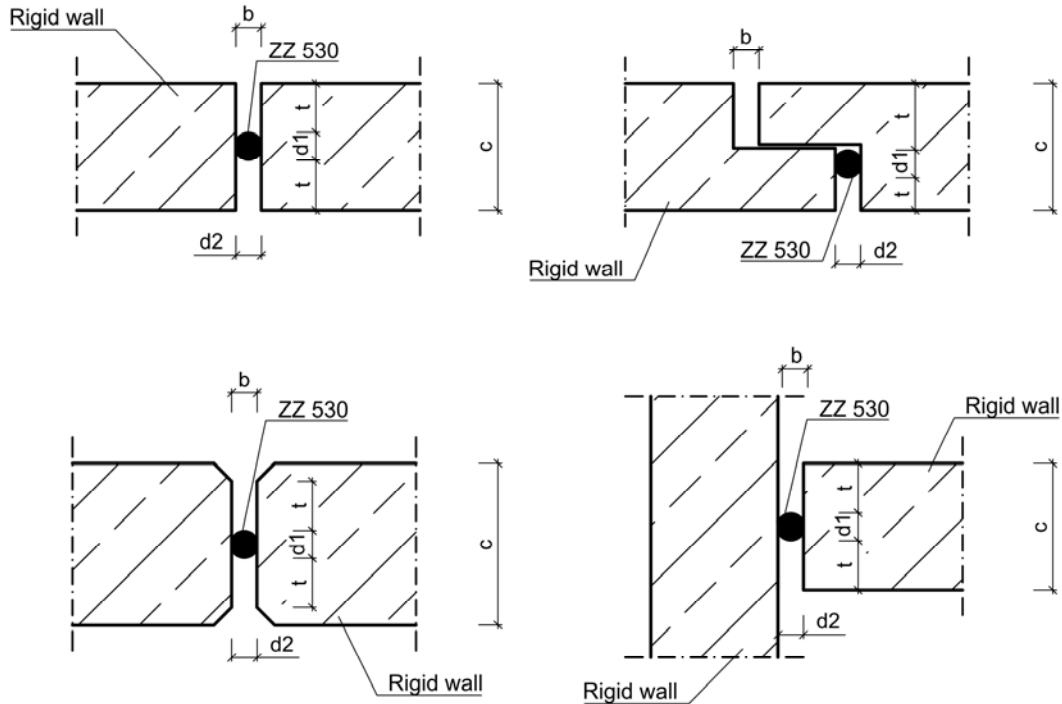

**Horizontal joints in rigid walls abutting a floor, ceiling or roof :**

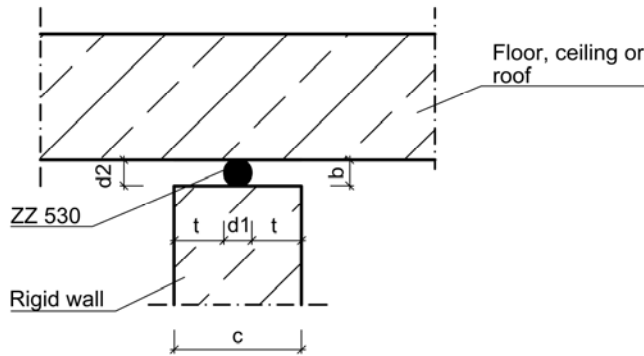

All dimensions in mm

Element of construction	Joint width b [mm] (Values in-between may be interpolated)	Insertion depth t [mm]	Wall thickness c [mm]	Height and width of ZZ 530 d1 and d2 [mm]	Fire resistance classification
Rigid wall	55 65 75	≥ 45 ≥ 22,5 ≥ 0	≥ 150	see ANNEX F-2 of the ETA	EI15- to EI90-V-X-F-W 55 to 75 EI15- to EI90-T-X-F-W 55 to 75

**ZZ G50**

**Lateral and shear movement capability 7,5%**

- Option 4: Installation of one Fire Protection Joint Seal ZZ 530 -

**ANNEX E-1**

**Lateral and shear movement capability 7,5 %**  
**Option 4: Installation of one Fire Protection Joint Seal ZZ 530**

**Horizontal joints in/ between rigid floors**

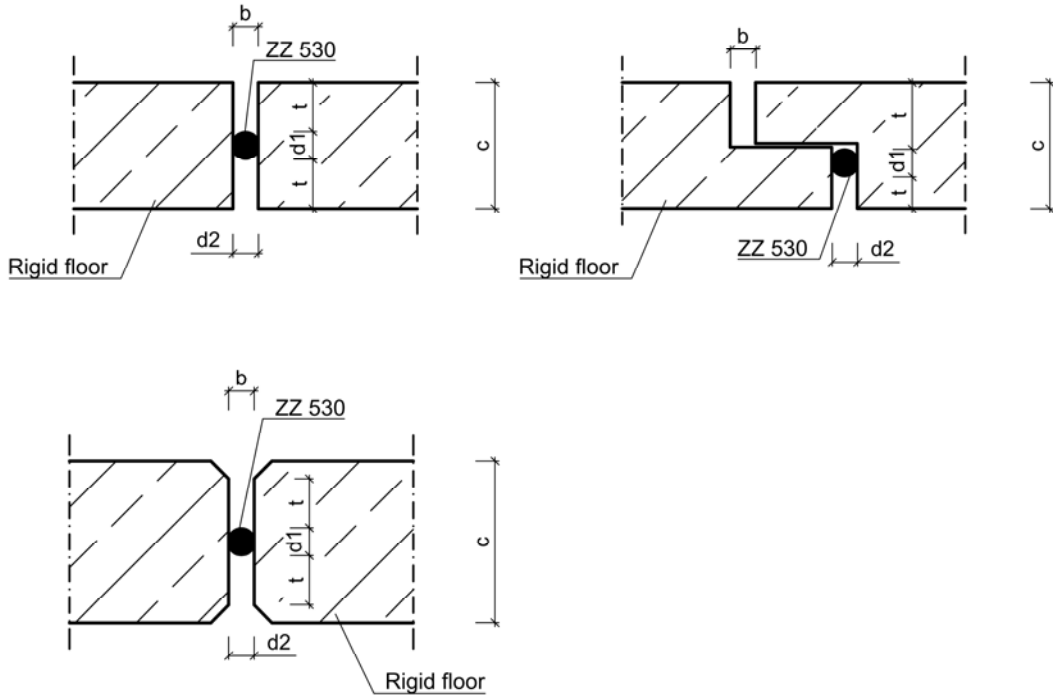

All dimensions in mm

Element of construction	Joint width b [mm] (Values in-between may be interpolated)	Insertion depth t [mm]	Floor thickness c [mm]	Height and width of ZZ 530 d1 and d2 [mm]	Fire resistance classification
Rigid floor	55 65 75	≥ 45 ≥ 22,5 ≥ 0	≥ 150	see ANNEX F-2 of the ETA	EI15- to EI60-H-X-F-W 55 to 75 EI90-H-X-F-W 75

**ZZ G50**

**Lateral and shear movement capability 7,5%**

- Option 4: Installation of one Fire Protection Joint Seal ZZ 530 -

**ANNEX E-2**

Lateral movement capability 25 %, shear movement capability 7,5 %  
See Option 1 (ANNEX B-1 and B-2 of the ETA) and Option 2 (ANNEX  
C-1 and C-2 of the ETA)

Minimum dimensions of Fire Protection Joint Seal ZZ 530

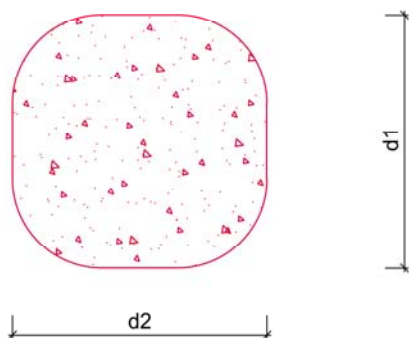

Joint width b [mm]	Minimum width ZZ 530 d2 [mm]	Minimum height ZZ 530 d1 [mm]
10	16	16
≤ 16	24	24
≤ 21	30	30
≤ 28	39	39
≤ 36	49	49

Only Option 1:

≤ 48	65	57
≤ 60	80	70

**ZZ G50**

- Option 1 and 2:

Minimum dimensions of Fire Protection Joint Seal ZZ 530 -

**ANNEX F-1**

Lateral and shear movement capability 7,5 %

See Option 3 (ANNEX D-1 and D-2 of the ETA) and Option 4 (ANNEX E-1 and E-2 of the ETA)

Minimum dimensions of Fire Protection Joint Seal ZZ 530

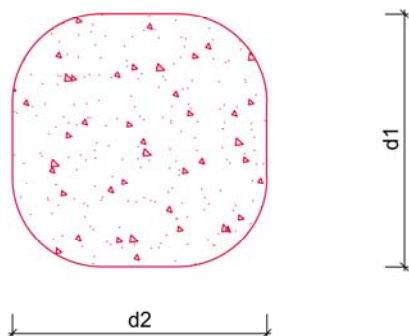

Joint width b [mm]	Minimum width ZZ 530 d2 [mm]	Minimum height ZZ 530 d1 [mm]
10	13	13
≤ 13	16	16
≤ 20	24	24
≤ 26	30	30
≤ 35	39	39
≤ 45	49	49
≤ 55	60	60
≤ 65	70	70
≤ 75	80	80

**ZZ G50**

- Option 3 and 4:

Minimum dimensions of Fire Protection Joint Seal ZZ 530 -

**ANNEX F-2**